

**Clark County
Regional Flood Control District**

Citizens Advisory Committee

May 27, 2021



Item # 20

- Wagon Trail Channel – Sunset Road to Teco Avenue – Clark County (*For possible action*)
 - a. Action to accept the project presentation



Wagon Trail Channel – Sunset Road to Teco Avenue

For
Clark County
Department of Public Works



By
Westwood Professional Services

Funded by



Project Vicinity

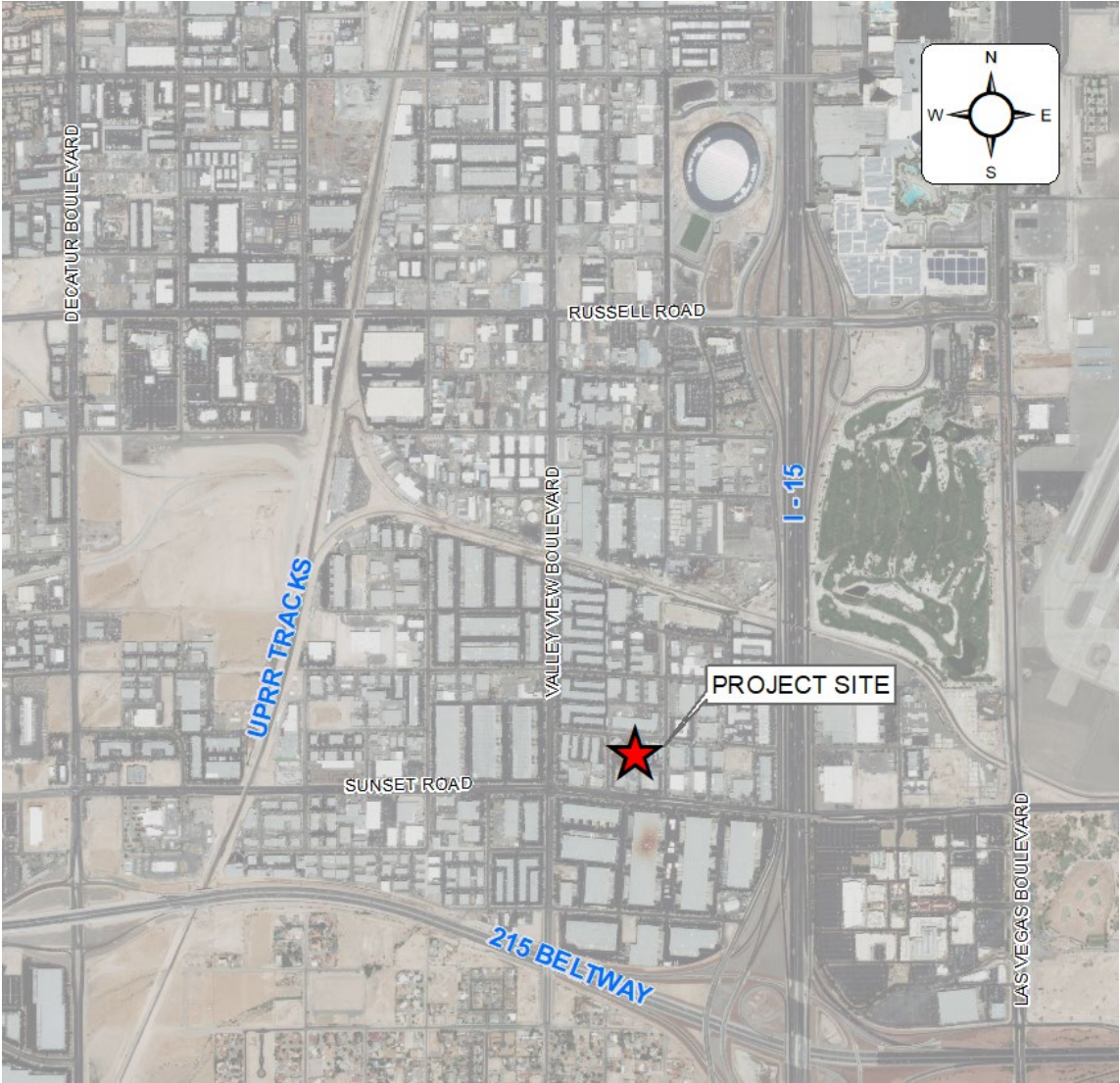

Project Overview



Project Components

- 632-LF OF 10'x4' RCB
- 498-LF OF 7' x 6' RCB
- ASSOCIATED DRAINAGE APPURTENANCES

Alignment

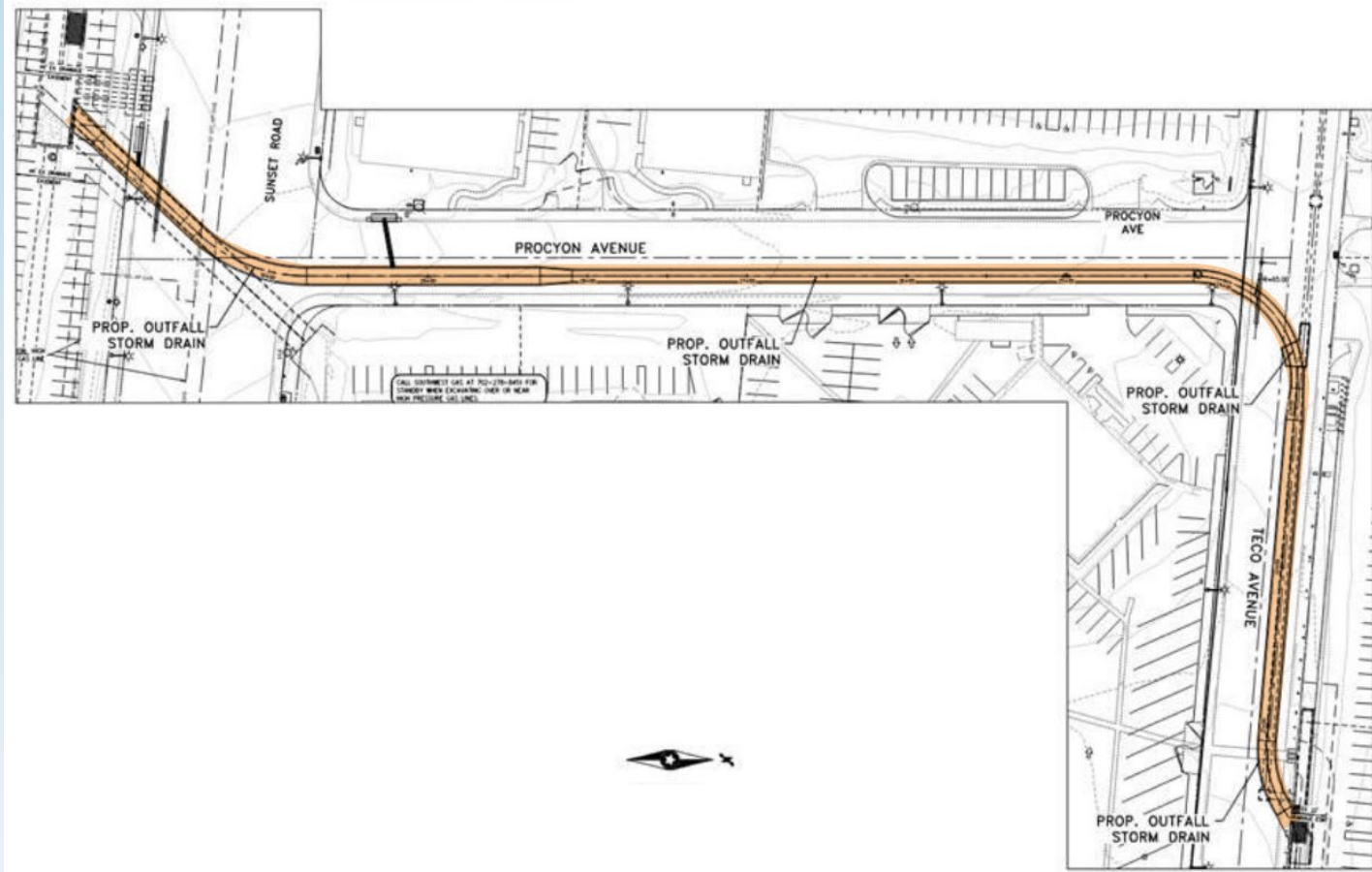

Westwood

Pre-Cast RCB Section

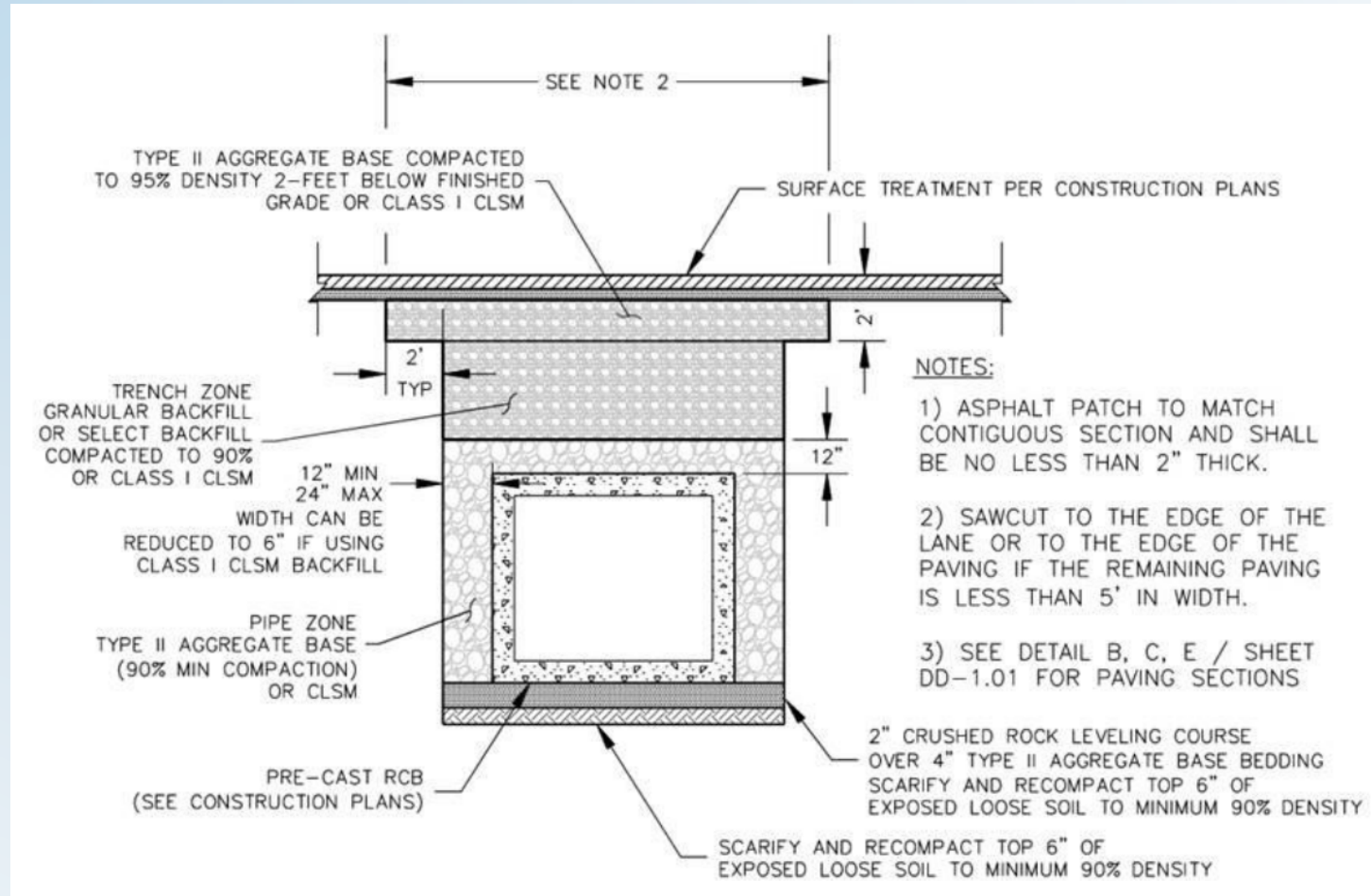

Cast-In-Place RCB Section

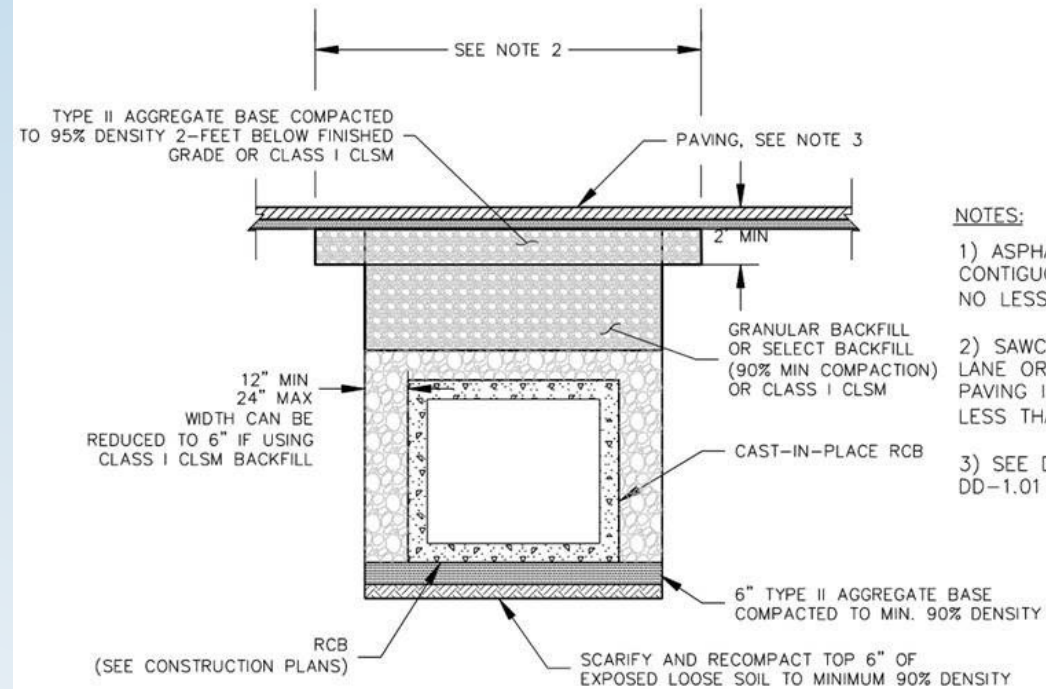

NOTES:

- 1) ASPHALT PATCH TO MATCH CONTIGUOUS SECTION AND SHALL BE NO LESS THAN 2" THICK.
- 2) SAWCUT TO THE EDGE OF THE LANE OR TO THE EDGE OF THE PAVING IF THE REMAINING PAVING IS LESS THAN 5' IN WIDTH.
- 3) SEE DETAIL B, C, AND E / SHEET DD-1.01 FOR PAVING SECTIONS

Existing Facilities

Upstream Bubbler Structure



Downstream Collection Grate



Project Cost

| Description | Design | Construction |
|----------------------------|----------------|--------------|
| Design Engineering | \$253,800 | - |
| Entity Design Labor | \$50,000 | - |
| Right-of-Way | \$50,000 | - |
| Environmental | \$15,000 | - |
| Construction | - | \$2,500,008 |
| Construction Management | - | \$250,000 |
| Clark County CM Labor Cost | - | \$50,000 |
| Subtotal | \$368,800 | \$2,800,008 |
| TOTAL | \$3,168,808.00 | |

Funding Eligibility Requirements

- Design documents are 90 percent complete
- All necessary rights-of-way have been obtained
- All necessary local, state, and federal permits including environmental have been satisfied

Construction Schedule

| | |
|------------------------------|--------------|
| Award of Bid | October 2021 |
| Construction Start Date | January 2022 |
| Project Duration | 7 Months |
| Construction Completion Date | August 2022 |

Questions?

Westwood